

8 7 6 5 4 3 2 1

F
E
D
C
B
A

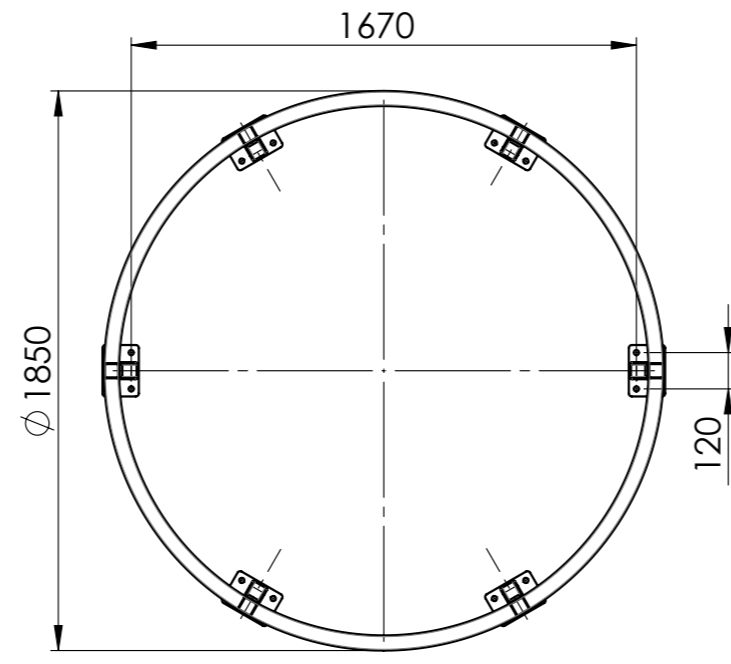
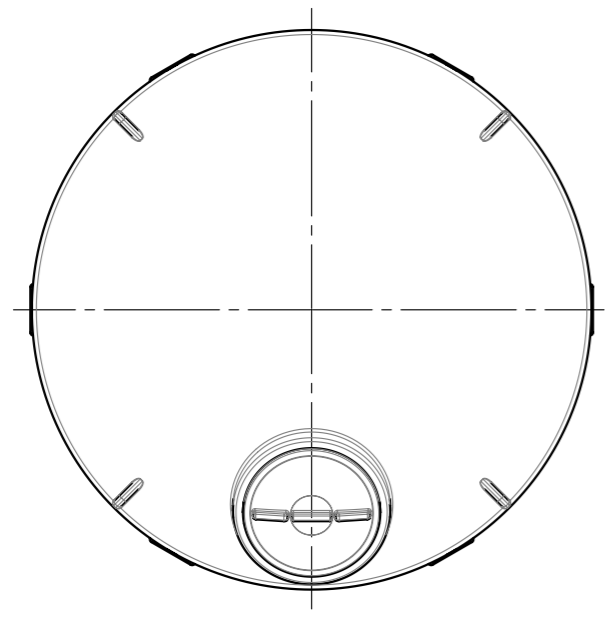
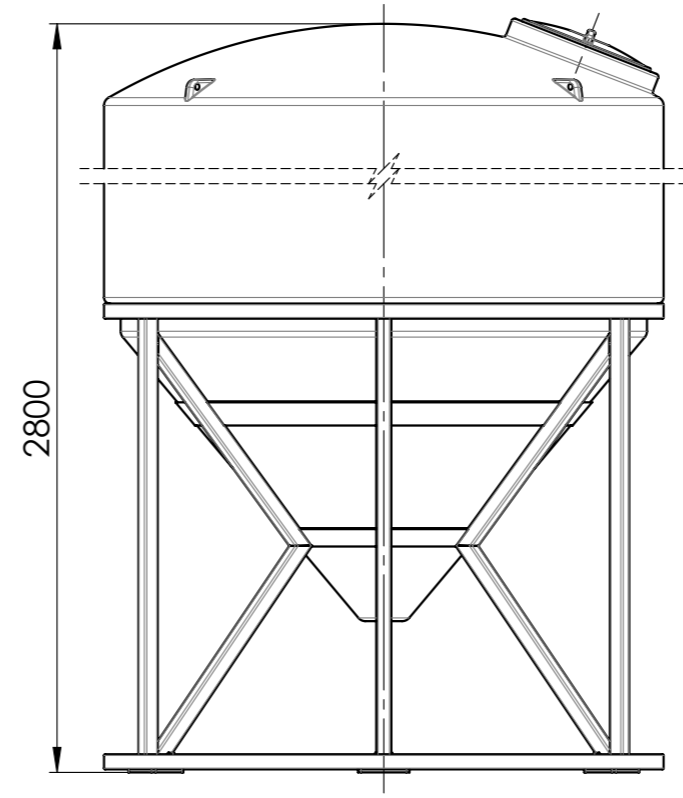
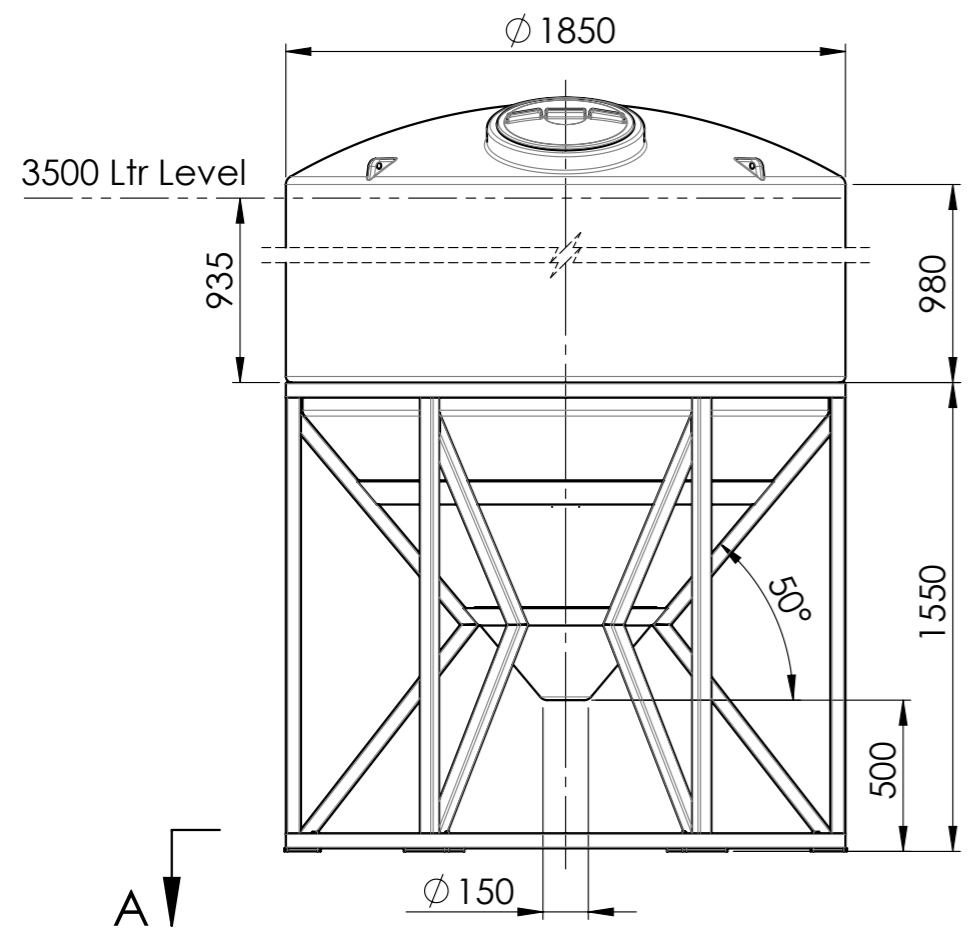

SECTION A-A

CLIENT APPROVAL	
<input type="checkbox"/> APPROVED	
<input type="checkbox"/> REVISE AND RESUBMIT	
<input type="checkbox"/> FOR INFORMATION ONLY	
DATE:	

SIGNATURE	



PROPRIETARY AND CONFIDENTIAL
 THIS DRAWING AND THE INFORMATION AND TECHNICAL DATA CONTAINED HEREIN ARE THE EXCLUSIVE PROPERTY OF PROMAX PLASTICS AND SHALL BE RETURNED TO THEM UPON REQUEST.
 THIS DRAWING CONTAINS PROPRIETARY AND CONFIDENTIAL INFORMATION FOR THIS PROJECT AND IS NOT TO BE MADE AVAILABLE TO 3RD PARTIES WITHOUT THE EXPRESS WRITTEN CONSENT OF PROMAX PLASTICS.

DO NOT SCALE DRAWING	
ORIGINAL ISSUE:	

OPP:	
AUTHOR:	SL
MATERIAL:	
WEIGHT:	

DISPLAY NAME/NUMBER: EXPRESS Industrial Cone Tank 3500 Ltr	
DWG NO. XICT03500-NI	A3
SCALE: 1:25	SHEET 1 OF 1

8 7 6 5 4 3 2 1